

VOLVO
115 281

Fig. 46-20. Fitting diaphragm

ragm so that they do not spin round. Remove the thrust washer and diaphragm, and take care of the distance washer in the centre of the diaphragm.

3. Fit the new diaphragm. Fit the distance washer in the centre of the diaphragm. Place the thrust washer on the diaphragm.
4. Fit and tighten up the nut. Hold securely the thrust washer and diaphragm so that they do not spin round when the nut is tightened up.
5. Fit the spring with the large contact surface facing the thrust washer, Fig. 46-21. Fit the cover. Fit the bolts evenly round the cover and tighten up.

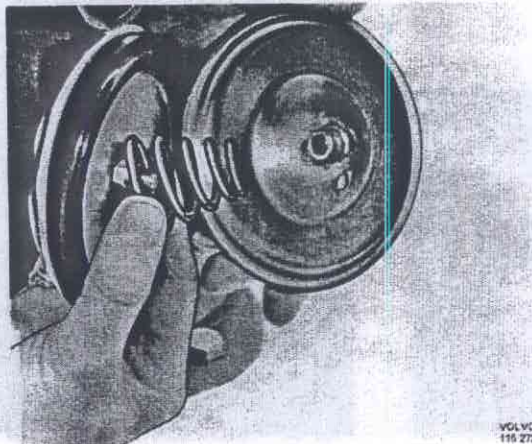

VOLVO
115 272

Fig. 46-21. Installing the spring



Fig. 46-22. Control cylinder

Adjusting the differential lock

1. Unscrew the wheel nuts on the wheel which is on the same side as the control cylinder (right-hand side).
2. Jack up the vehicle and remove the wheel.
3. Remove the bolts securing the control cylinder cover, Fig. 46-22. Remove the cover.
4. Remove the spring. Remove the nut on the pull rod. Remove the diaphragm and the thrust washers. Take care of the washer in the centre of the diaphragm.
5. Lift up the pull rod and adjust the nut, Fig. 46-23, so that it is flush with the gauge 6133. If there is no gauge, the distance should be 9 mm (0.36") between the holed nut and the nut, when the differential lock is engaged.

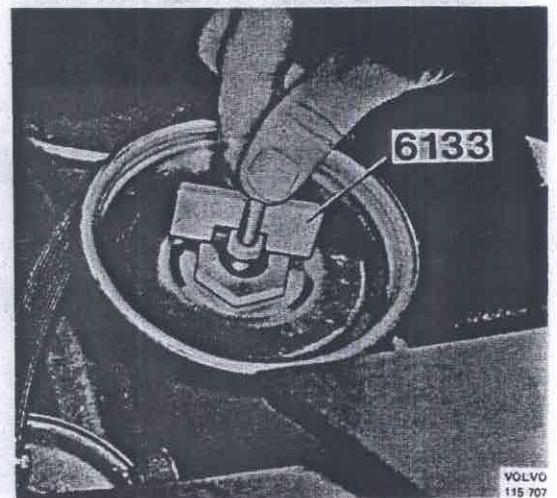

VOLVO
115 707

Fig. 46-23. Adjusting the pull rod

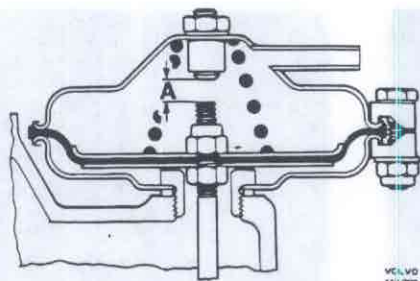

A = 6 3/8 turns (9,2 mm)

Fig. 46-24. Adjusting the bolt

6. Fit the thrust washer and diaphragm. Fit the copper washer in the centre of the diaphragm. Fit the other thrust washer.
7. Fit on the upper nut. Hold securely the lower nut, the thrust washers and the diaphragm so that they do not rotate when the nut is tightened up.
8. Fit the spring with the large contact surface facing the thrust washer, Fig. 46-24. Fit the cover. Fit the bolts evenly round the cover and tighten up.
9. Remove the lock nut for the bolt on the cover. Screw down the bolt so that it bottoms against the thrust rod. Then screw it back 6 3/8, approx 9,2 mm (0.36") turns and lock it with the lock nut, Fig. 46-24.
10. Check with the control for the differential lock that the lock engages and disengages properly.

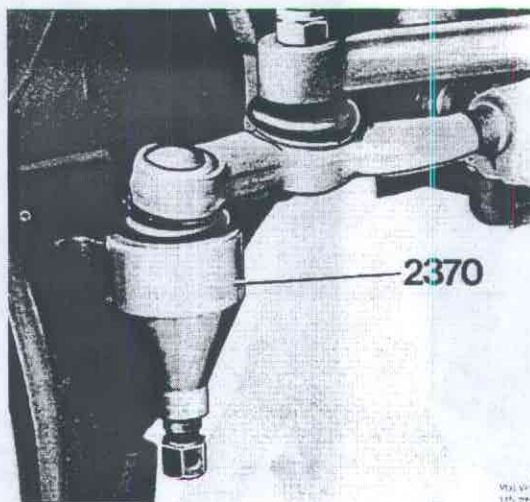

Fig. 46-25. Removing the ball joint

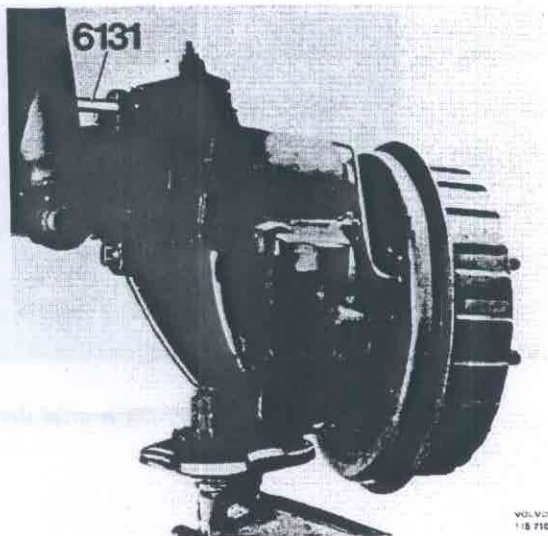

Fig. 46-26. Removing the wheel carrier

Replacing the differential carriers

Removing the front differential carrier

1. Release the wheel nuts on both wheels. Jack up the vehicle.
2. Remove the wheels.
3. Drain the oil from the differential carrier. Remove the nut on the ball joints for the steering rods. Disconnect the ball joint from the steering arm with 2370, Fig. 46-25.
4. Remove the plate for the hollow rubber spring. Remove the upper bolts and fit the guide pins 6131, see Fig. 46-26.
5. Remove the lower bolts securing the wheel carrier housing to the front axle casing. Place a jack under the wheel carrier housing.
6. Pull out the wheel carrier housing with drive shaft at least 100 mm (4") or the maximum length permitted by the brake hoses. Remove the jack and support under the wheel carrier housing.
7. Disconnect the other wheel carrier housing in the same way.
8. Remove the propeller shaft from the differential carrier flange, Fig. 46-27.
9. Remove the nuts securing the differential carrier and remove the carrier.
10. For replacement of the differential sleeve, see under "Replacing the differential sleeve".

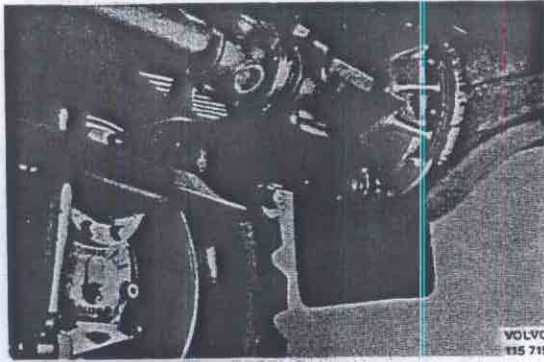

Fig. 46-27. Differential sleeve

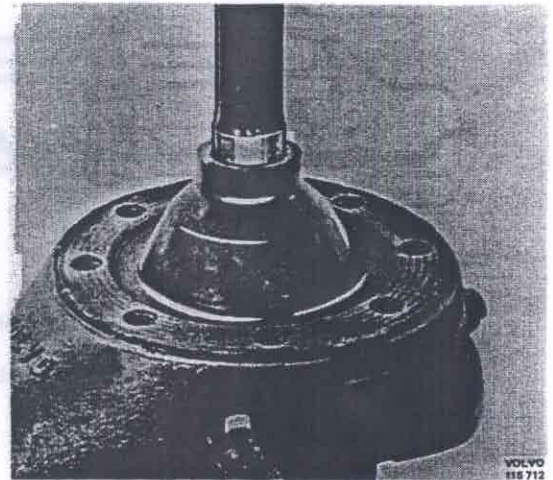

Fig. 46-29. Location of rubber dust cover

Installing the front differential carrier

1. Check the selector fork for the differential gear for wear. Concerning eventual replacement of the differential lock or fork, see under "Replacing the differential sleeve".
2. Clean the contact face of the casing and coat it with sealing agent. Make sure that the flange sleeve of the differential lock on the differential carrier is on the right side. Place the differential carrier in position. Fit the washers and nuts in position and tighten up the carrier.

3. Fit the propeller shaft. Tighten the bolts to a torque of 55-65 Nm (5.5-6.5 kpm = 40-47 lbft).

4. **NOTE!** Check that the rubber dust cover for the drive shaft is fitted properly on the steering knuckle support, see Fig. 46-29, before fitting the wheel carrier and support together.

Lift up the drive shaft while pushing in the differential carrier, Fig. 46-30. When the drive shaft touches the differential, rotate the differential carrier flange while pushing the carrier to the bottom at the same time.

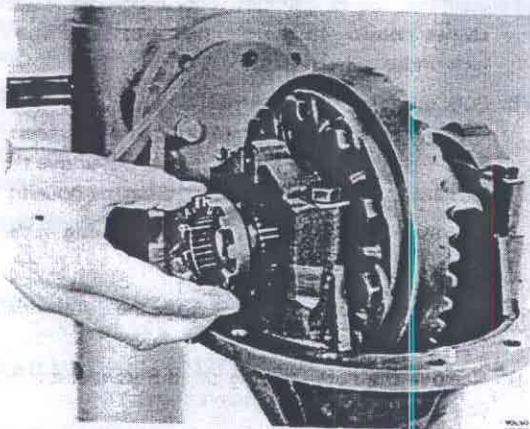

Fig. 46-28. Flange sleeve

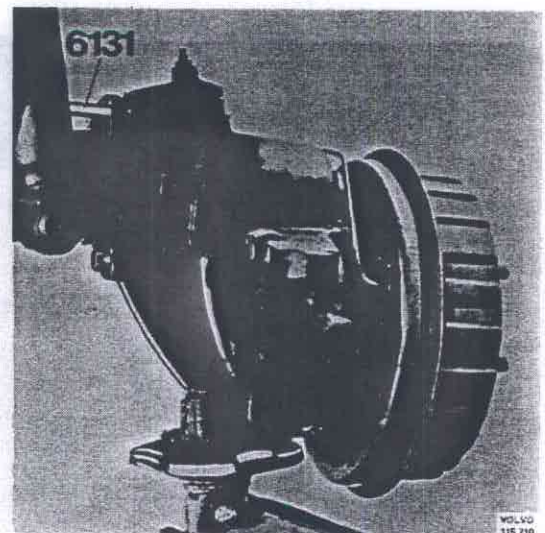

Fig. 46-30. Fitting the carrier

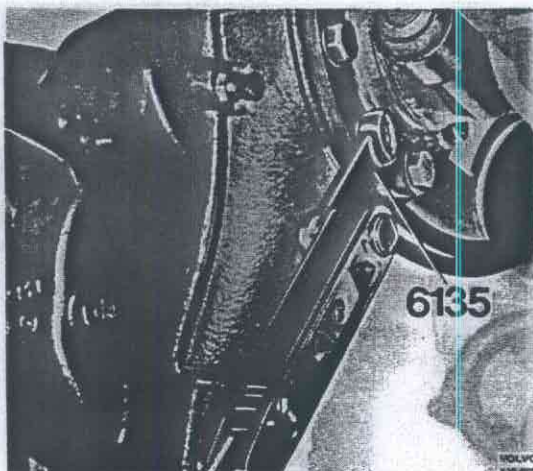

Fig. 46-31. Tighten the nuts

5. Fit the bolts round the front axle casing. Remove the guide pins. Tighten the bolts to a torque of 100–120 Nm (10–12 kpm = 72–87 lbftf). Use 6135, see Fig. 46-31. Remove the jack.
6. Fix the plate on for the hollow rubber spring.
7. Fit the lower steering rod. Check that the lubricating nipple is not damaged.
8. Fit the other wheel carrier housing in the same way (points 4–6).
9. Fill the carrier with oil. Concerning quantity and type, see under "Data".
10. Adjust the differential lock, see the separate instructions.

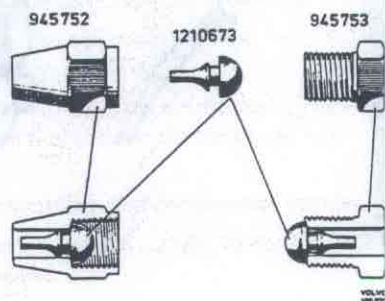

Fig. 46-32. Sealing nipples

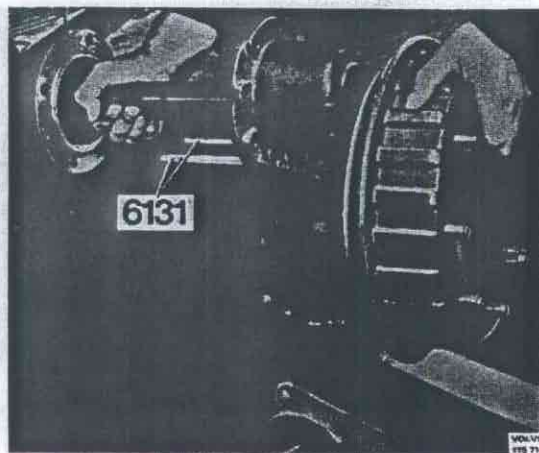

Fig. 46-33. Removing the wheel carrier

11. Fit the wheels. Lower the vehicle and tighten the wheel nuts to a torque of 210 Nm (21 kpm = 152 lbftf).

Removing the rear differential carrier

1. Release the wheel nuts on both rear wheels. Jack up the rear of the vehicle.
2. Remove the wheels.
3. Drain the oil from the differential carrier.
4. Remove the shock absorber from its lower attachment. Disconnect the brake line from the wheel cylinder. Plug the line with a sealing nipple, see Fig. 46-32. Volvo nos. 245752 + 1210673.
5. Place a jack under the wheel carrier housing, see Fig. 46-33. Remove the bolts securing the wheel carrier housing to the rear axle casing. Allow two bolts to remain. Tap carefully on the bolts so that the housing loosens from the casing.
6. Remove the bolts and pull out the wheel carrier housing with the drive shaft.
7. Remove the other wheel carrier housing in the same way.
8. Remove the propeller shaft from the differential carrier flange, Fig. 46-27.
9. Remove the nuts securing the differential carrier and remove the carrier.
10. For replacement of the differential sleeve, see under "Replacing the differential sleeve".

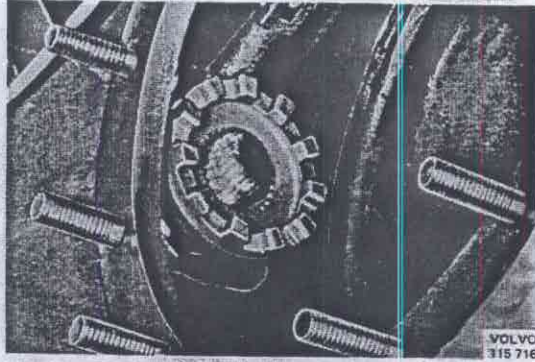

Fig. 46-34. Differential carrier

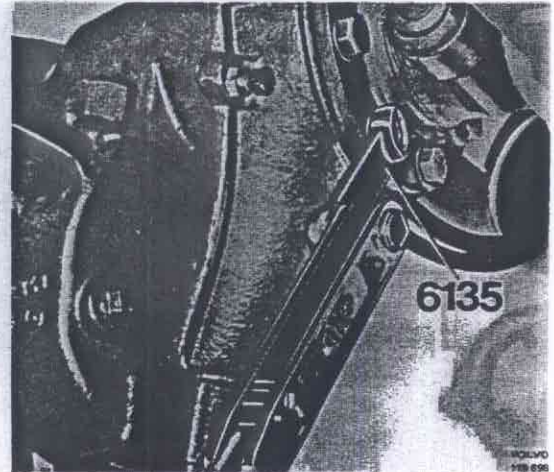

Fig. 46-36. Tighten the nuts

Installing the rear differential carrier

1. Check the selector fork for the differential lock for wear. In the event the lock or the fork has to be replaced, see the special instructions. Lift up the flange and hold it in position with a suitable tool, see Fig. 46-35.
2. Clean the contact face of the casing and coat it with sealing agent. Check that the differential lock flange sleeve on the differential carrier is on the right side. Place the differential carrier in position. Fit washers and nuts in position and tighten up the carrier.
3. Fit the propeller shaft. Tighten the bolts to a torque of 55-65 Nm (5.5-6.5 kpm = 40-47 lbftf).

4. Remove the tool holding the flange. Fit two guide pins 6131 in the lower holes of the wheel carrier housing, Fig. 46-33. Place the housing on a jack. Lift up the carrier so that the guide pins can enter the rear axle casing. Rotate the differential carrier flange while pushing in the carrier at the same time.
5. Fit the bolts round the casing. Remove the guide pins. Tighten the bolts to a torque of 100-120 Nm (10-12 kpm = 72-87 lbftf). Use 6135, see Fig. 46-36. Remove the jack.
6. Fit the shock absorber. Fit and tighten up the brake pipe.

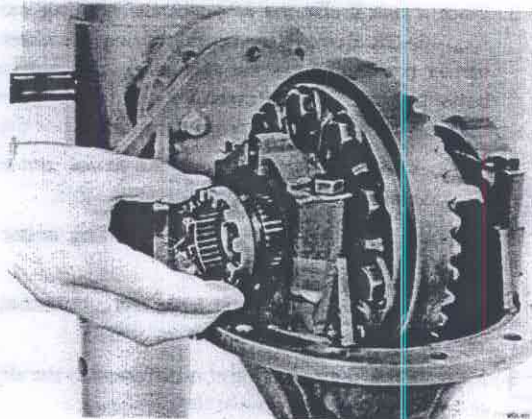

Fig. 46-35. Differential lock flange

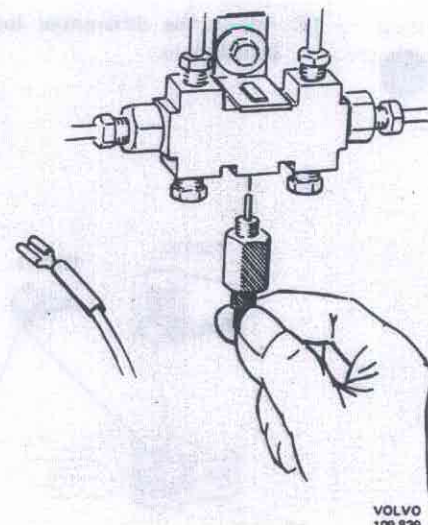
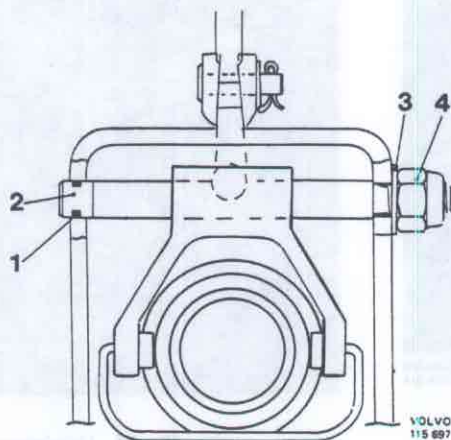

Fig. 46-37. Removing the contact



- | | |
|-----------|-----------|
| 1. O-ring | 3. Washer |
| 2. Shaft | 4. Nut |

Fig. 46-38. Differential sleeve

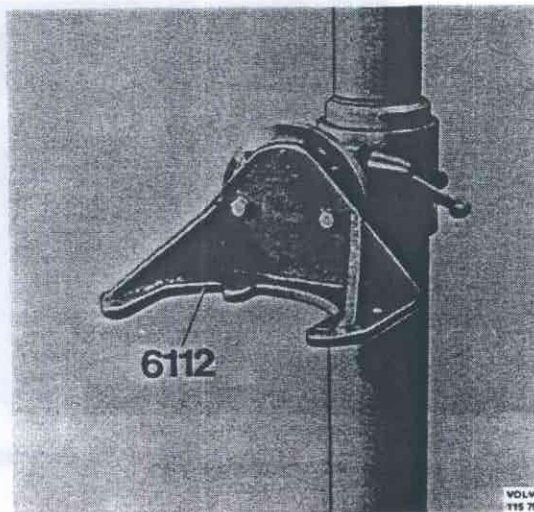

Fig. 46-39. Fixture for the differential carrier

7. Fit the other wheel carrier housing in the same way. Bleed the wheel cylinders on the rear wheels. The electrical contact for the pressure difference should be removed, see Fig. 46-37, during the bleeding. If a bleeder unit is used, the working pressure should be 0.2 MPa (2 kp/cm² = 28 lbf/in²). For more detailed instructions with regard to bleeding, see Part 5. Fill the differential carrier with oil. Concerning quantity and type, see under "Data".
8. Fit the wheels.
9. Lower the vehicle. Tighten the wheel nuts to a torque of 210 Nm (21 kpm = 152 lbftf).

Replacing the differential sleeve (with differential carrier removed)

1. Remove the nut from the shaft (Fig. 46-38). Drive out the shaft with a plastic mallet.
2. Remove the sleeve from the drive shaft. Remove the sleeve from the fork.
3. Check that the fork, or the shaft, is not damaged. If necessary, replace the requisite parts.
4. Fit the new sleeve on the fork. Push the sleeve onto the drive shaft.
5. Fit a new O-ring on the shaft. Place the shaft in position. Fit and tighten up the nut.

Disassembling the differential carrier

Special tools: 1801, 2261, 2392, 2567, 2837, 4030, 6014, 6115.

1. Clean the outside of the carrier. Place the carrier in fixture 6112, Fig. 46-39.

2. Check to make sure the bearing caps are marked.
3. Bend up the tabs on the lock washer for the cap bolts. Remove the bolts and the lock rings for the adjuster nuts.
4. Remove the cap bolts. Remove the caps.
5. Remove the differential housing with adjuster nuts and bearing.
6. Remove the oil scraper and spring, Fig. 46-40.

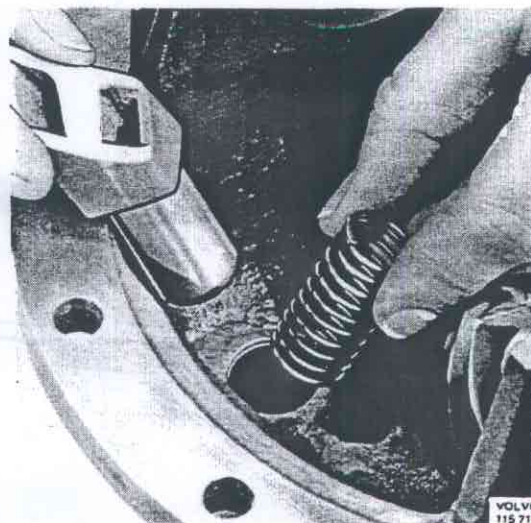

Fig. 46-40. Removing the oil scraper

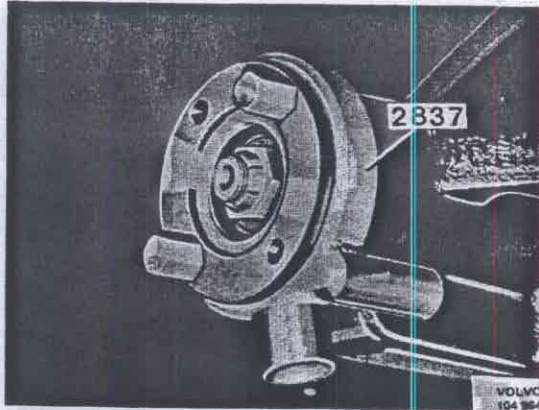

Fig. 46-41. Fitting a puller

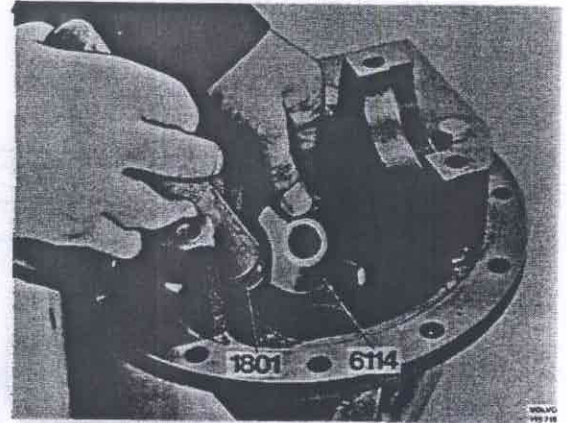

Fig. 46-44. Driving out the seal

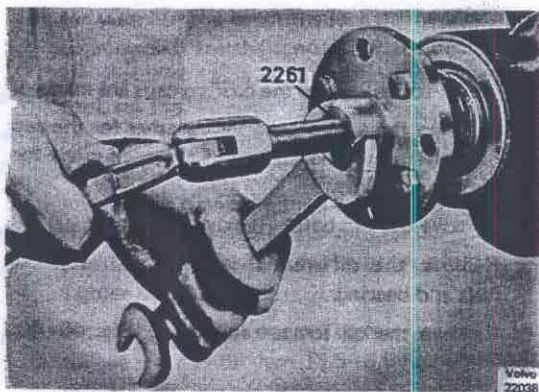

Fig. 46-42. Removing the flange

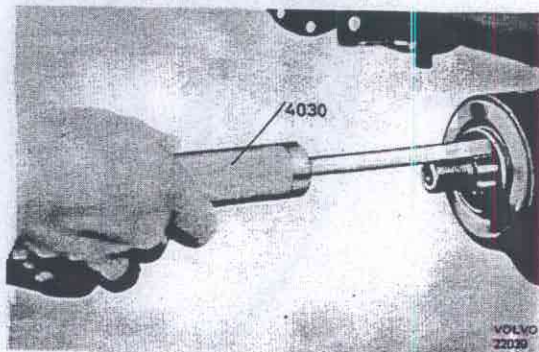

Fig. 46-43. Removing the seal

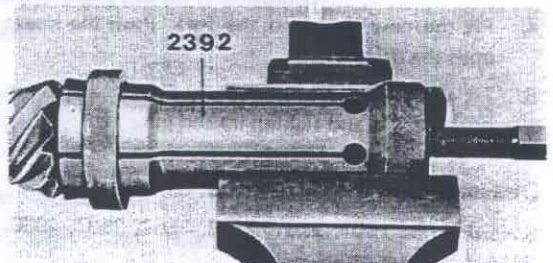
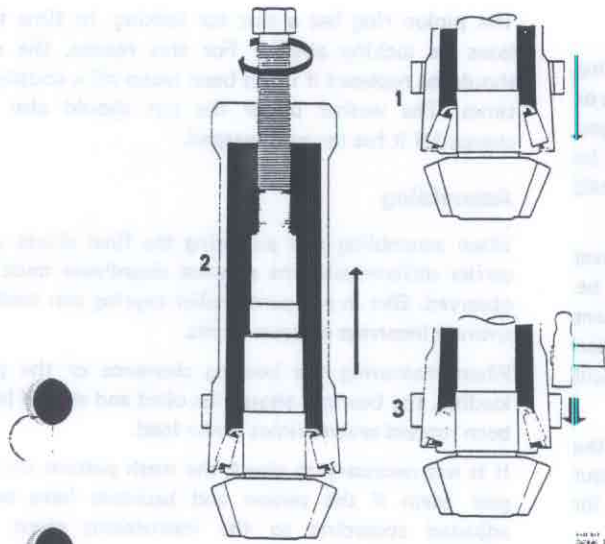

Fig. 46-45. Removing the bearing

7. Turn the carrier. Fit counterhold 2837 on the flange, Fig. 46-41. Remove the flange nut.
8. Remove the counterhold. Fit 2261 on the flange, Fig. 46-42. Remove the flange. Pull out the flange seal with 4030, see Fig. 46-43. Remove the oil deflector plate.
9. Drive out the pinion with a plastic mallet. Take care of the shims and spacer sleeve.
10. Turn the carrier. With 6014 + 1801 drive out the flange seal, front bearing and outer race, Fig. 46-44.
11. Turn the carrier. Drive out the outer race for the rear bearing with 6115 + 1801.
12. Remove the bearing from the pinion with 2392, Fig. 46-45. Note how the tool is attached, Fig. 46-46.



1. Puller is pushed over the rollers
2. Rollers pulled up
3. Circlip knocked tight

Fig. 46-46. Fitting the puller

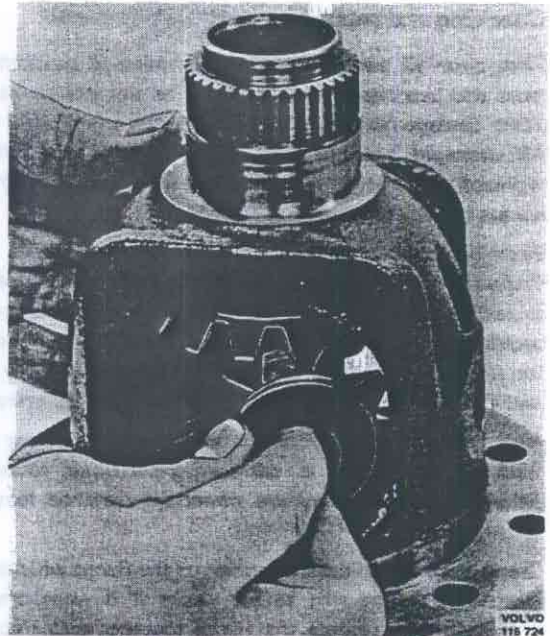

Fig. 46-48. Removing the washer

Disassembling a differential housing

1. Fix the housing in a vice. Remove the bolts securing the crown wheel. Remove the crown wheel.

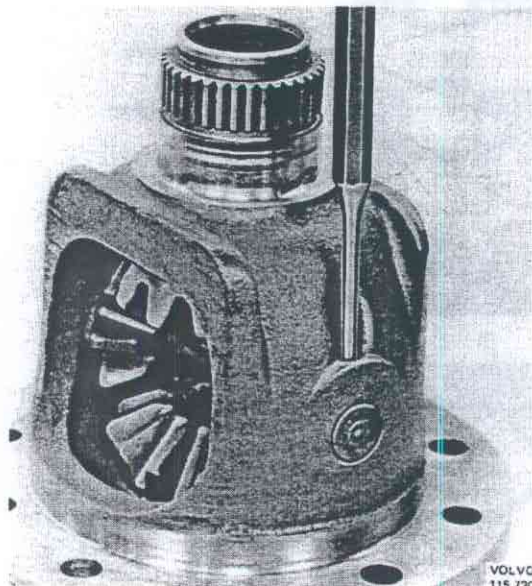

Fig. 46-47. Driving out the lock pin

2. Drive out the lock pin, Fig. 46-47, which holds the shaft for the differential gears.
3. Drive out the shaft. Rotate the differential side gears. Remove the pinions and thrust washers, Fig. 46-48. Remove the differential side gears and washers.
4. Remove the differential bearings with 2567, Fig. 46-49.

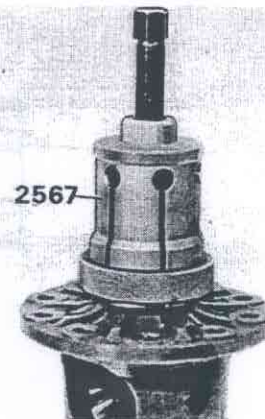

Fig. 46-49. Removing the bearing

Checking and replacing parts

First clean all parts thoroughly. Examine all bearing races and bearings. There must not be any scoring or other damage on the bearings, rollers or roller cages. All damaged bearings and bearing races are to be replaced and the bolts for the crown wheel should always be replaced.

Examine both the pinion and crown wheel thoroughly for damage to the gear teeth. This can be caused by incorrect running-in, wrong oil, insufficient backlash or incorrect tooth mesh. Unless the reason for the seizing is removed at an early stage, this will lead eventually to entirely ruined gears.

Also check the differential gears for damage to the teeth. If any gear is damaged replace all four differentials, since they are nowadays matched for better meshing.

Check also the cylindrical section of the flange which enters the sealing ring to see where it is worn or scored. If it is, replace the flange together with the sealing ring.

The pinion ring has a slot for locking. In time this loses its locking ability. For this reason, the nut should be replaced if it has been taken off a couple of times. The washer under the nut should also be changed if it has become warped.

Assembling

When assembling and adjusting the final drives and carrier differentials, the greatest cleanliness must be observed. Dirt in a tapered roller bearing can lead to entirely incorrect measurements.

When measuring the bearing clearance or the pre-loading, the bearings should be oiled and should have been rotated several times under load.

It is not necessary to check the mesh pattern on the gear teeth if the pinion and backlash have been adjusted according to the instructions given for assembling the final drive.

Washers and shims of different thicknesses are fitted in some places (see Fig. 46-50) in order to obtain correct clearance.

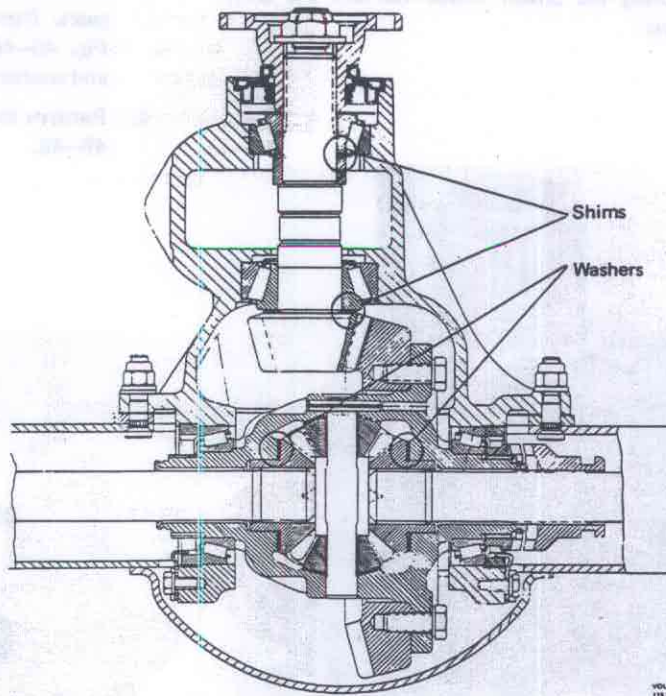

Fig. 46-50. Shims or washers