

KOBKLO

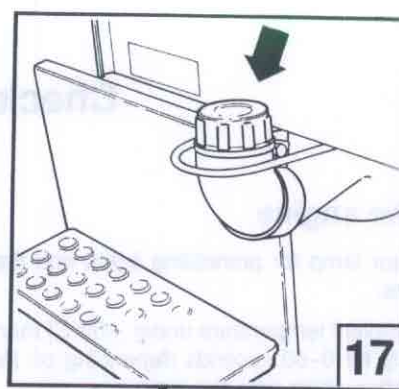

Gearboxes R/SR 1400 and R/SR 1700

- 1 Cover over oil filter
- 2 Oil filter

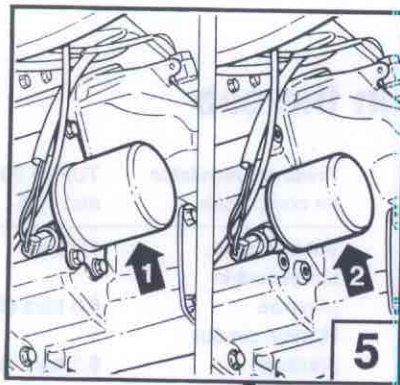
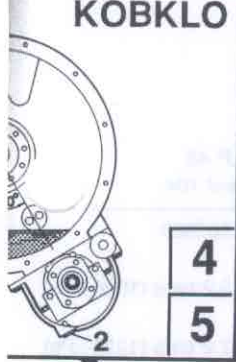
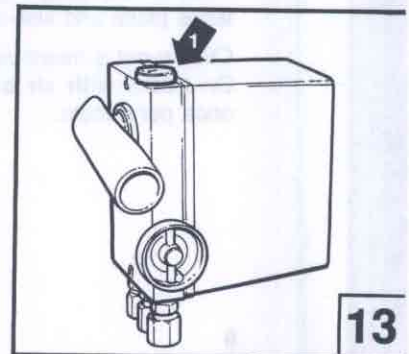
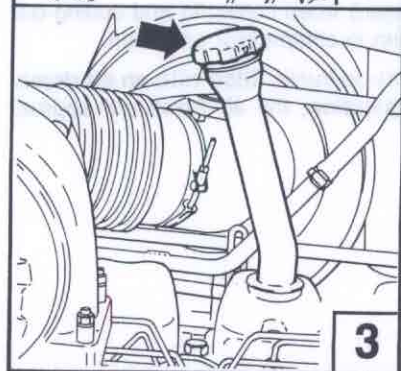
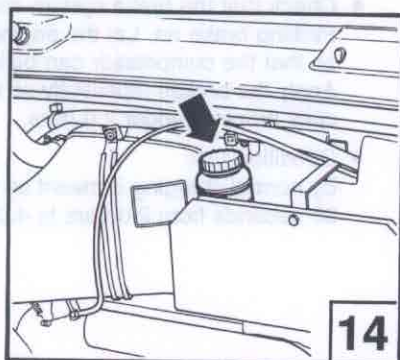
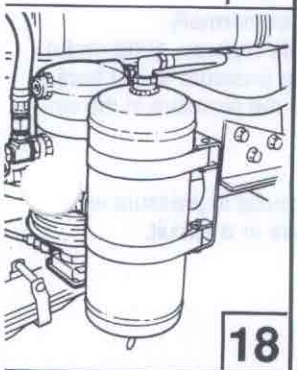
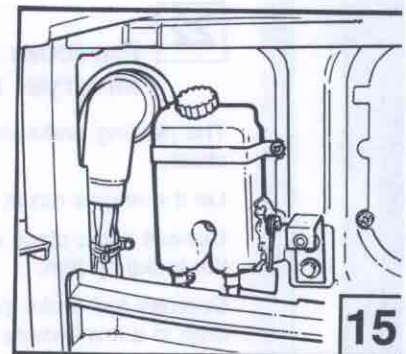
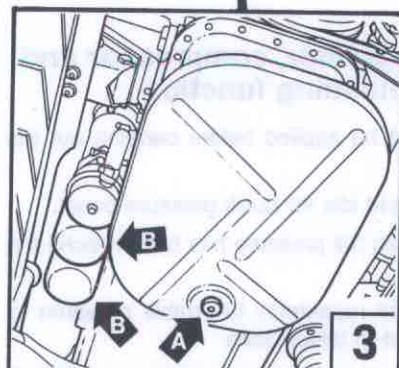
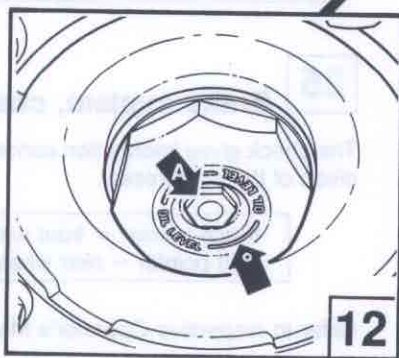
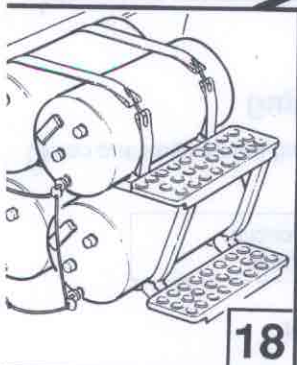
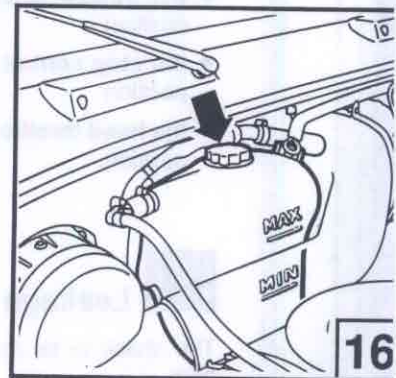
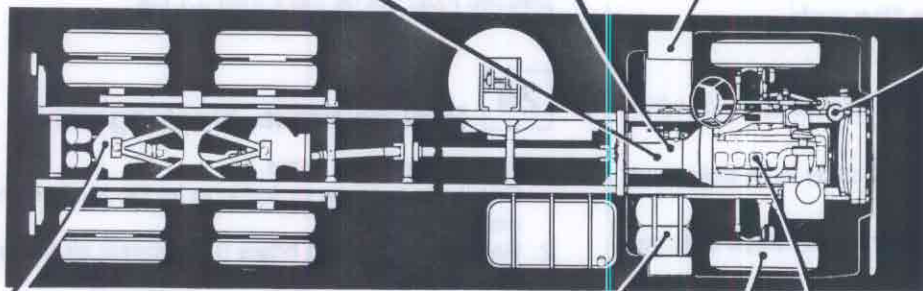

A Draining oil sumn

Checks in the cab

19 Starting the engine

Check that the indicator lamp for preheating lights and that preheating commences.

With a cold engine (coolant temperature under +50°C) there is automatic preheating for 0–50 seconds depending on the coolant temperature, after which time the lamp goes out.

With a warm engine (coolant temperature above +50°C) the lamp goes out within a few seconds.

If the indicator lamp lights longer than one minute after starting, this indicates a faulty starting heater.

Refer to the Operator's Manual: Starting the engine.

20 Engine controls in the cab

Check that:

- the **throttle pedal** moves freely and returns to its initial position
- the **stop control** moves freely and stops in its pulled-out position
- the **hand throttle control** moves freely and stops in its set position.

21 Leakage check, service brake circuits

The check to be carried out with a system pressure of 7.0 bars.

Depress the brake pedal and check that no air leaks from the service brake circuits.

22 Pressure regulator, compressor and air dryer unloading function

The parking brake must be applied before carrying out the check.

Let the engine run at rapid idle for quick pressure boost.

Cut-out takes place when full pressure has been reached in the brake system.

Depress the brake pedal repeatedly to enable pressure to drop to a level where **cut-in** takes place.

Observe the gauge (gauges) when cutting-in and cutting-out takes place and also listen to compressor operation.

Cutting-out is heard clearly on trucks **fitted with an air dryer**. On trucks **with air suspension**, the air blows out approx. once per minute.

Pressure regulator for compressor	TUFLO 500 and 15.5	LP 48 and 704
Volvo Part no.	1505047	1607889
Lowest cut-in pressure	6.3 bars (630 kPa)	10.2 bars (1020 kPa)
Highest cut-out pressure	8.1 bars (810 kPa)	12.2 bars (1220 kPa)
Max. difference between cut-in and cut-out pressure	1.0 bar (100 kPa)	1.6 bars (160 kPa)

23 Pressure drop, service brake circuits

The check is carried out with a system pressure of 7.0 bars.

Max. pressure drop during 1 minute with the brake pedal depressed must not be more than 0.1 bar.

24 Parking brake, blocking valve

1. Apply the parking brake.
Check the function by trying to let the truck pull with high gear engaged.
2. Release the parking brake (with normal air pressure), approx. 6.0 bars.
The blocking valve should be pushed in.
Check that the brake releases by allowing the truck to
3. Check the blocking valve.
The parking brake tank must have a pressure of at least approx. 5.5 bars in order to keep the valve in the pushed-in position. This is the same pressure required to release the parking brake.

NOTE! If the control button sinks by itself to the pushed-in position, this indicates leakage in the valve.

25 Brake system, charging

The check gives information concerning the function and condition of the compressor.

White pointer = front wheel circuit
Red pointer = rear wheel circuit

Refer to respective Operator's Manual.

- Check that the brake system charges normally.
Parking brake on. Let the engine idle (approx. 1000 r/min) so that the compressor can build up pressure to 7.0 bars. Apply the brakes repeatedly so that the pressure in the circuits drops to under 2.0 bars.
- Condition test:
By normal charging is meant an increase in pressure within 30 seconds from 2.0 bars to 4.0 bars in a circuit.

TBH = Compressed-air brakes, hydraulic

By normal charging it is meant an increase in pressure within 20 seconds from 2.0 bars to 4.0 bars in a circuit

NOTE! Both the air tanks are charged first when pressure exceeds 6.0 bars.

26 Pedal, footbrake valve

Check that:

- the footbrake pedal is easy to depress without binding. The pedal should return quickly and correctly.
- the pedal play is approx. 5–10 mm.
- the brake valve is firmly in position. Check for possible wear in the pedal journalling.
- the rubber pad is not damaged or worn.

27 Gear lever, clutch pedal

Refer to respective Operator's Manual.

1. The gear lever is checked with the engine running.
 - Operate the gear lever controls for range and split. Listen for noise from the gearbox when passing neutral, the indicator lamp should light up when high split is engaged.
 - Check front wheel drive and high and low gear controls.
 - Check that there is no excessive play in the lever.
2. Check that:
 - the clutch pedal is easy to depress without binding. The pedal should return quickly and correctly.
 - the clutch pedal play is approx. 5–10 mm.
 - the clutch pedal rubber pad is not damaged or worn.

28 Bogie lift

Refer to respective Operator's Manual.

Operate the bogie lift by pushing in the switch in the upper and lower positions.

29 Hinges, door stop, lock, weatherstrips

Check that:

- the hinges do not bind
- the door stops are intact
- the door lock assembly is securely in position, adjust if necessary
- the lock catches in two positions
- the weatherstrips are intact and securely fitted.

Normal charging

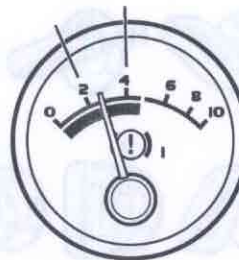

Warning lamp goes out

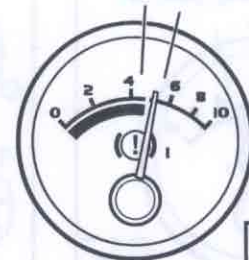

21

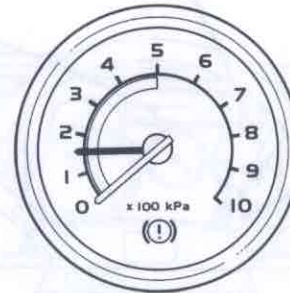

21 22 23 25

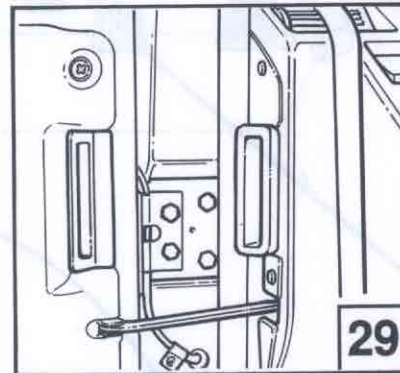

29

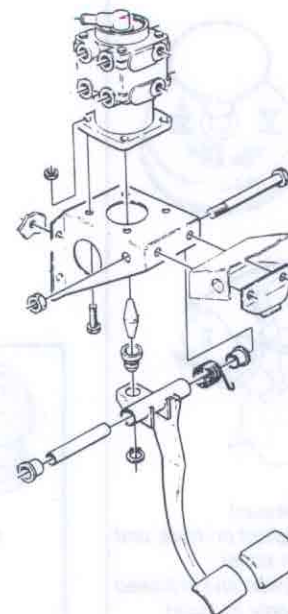

26

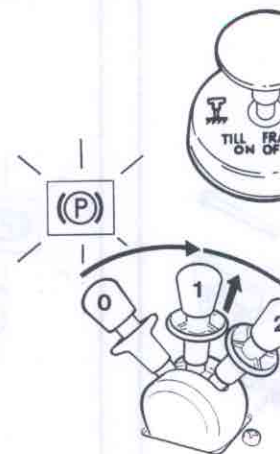

- 0 Parking brake released
- 1 Parking brake applied on service brakes on trailer
- 2 Parking brake applied and position (applies only to t

Warning lamp goes out

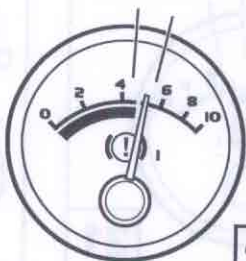

21

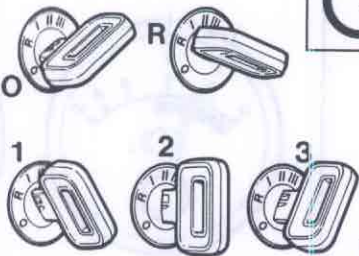

19

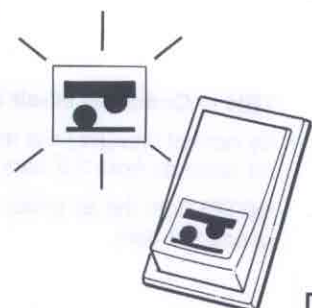

28

2 Preheat

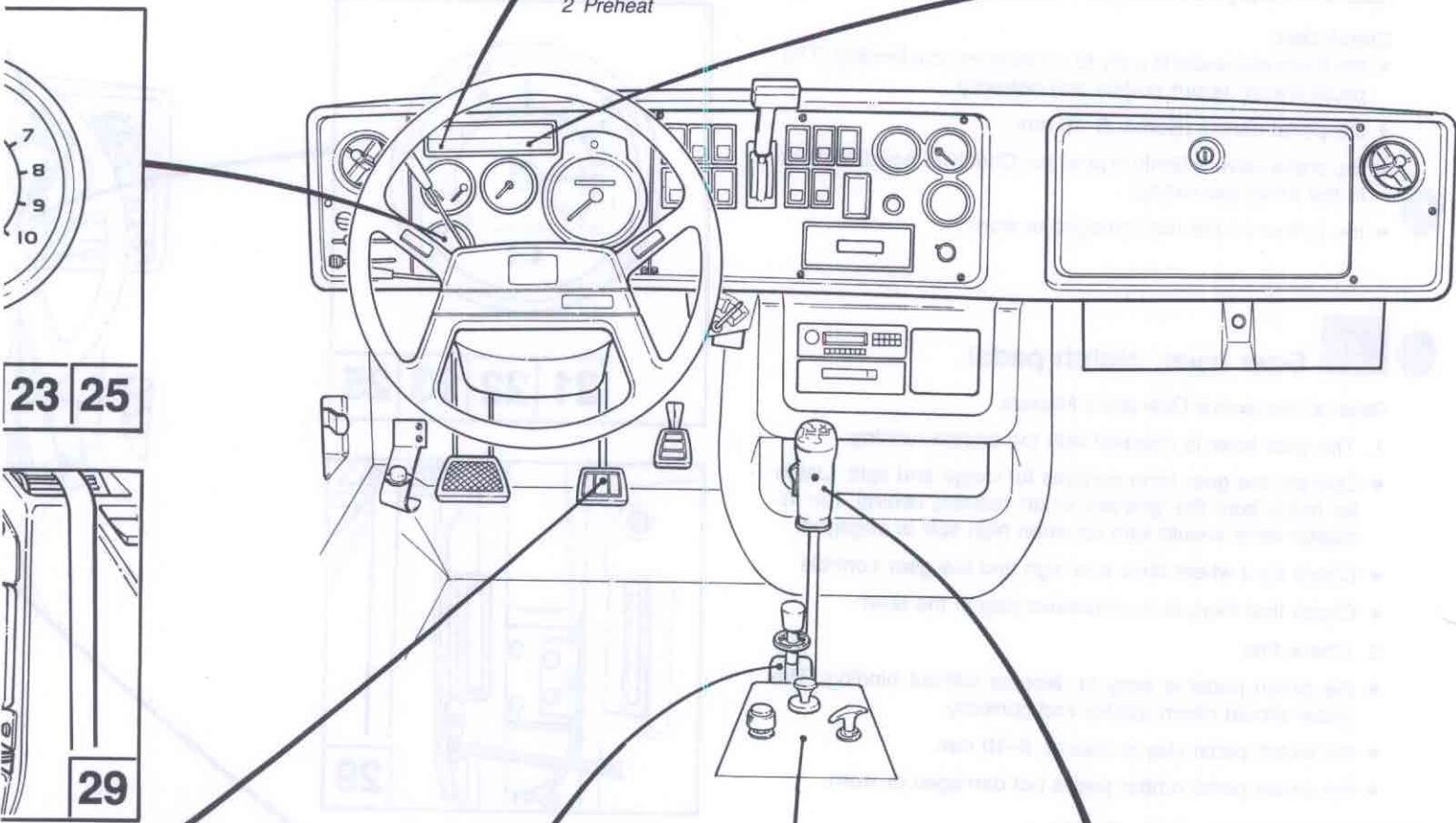

23 25

29

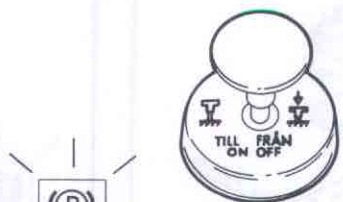

- 0 Parking brake released
- 1 Parking brake applied on truck and service brakes on trailer
- 2 Parking brake applied and in locked position (applies only to truck)

26

24

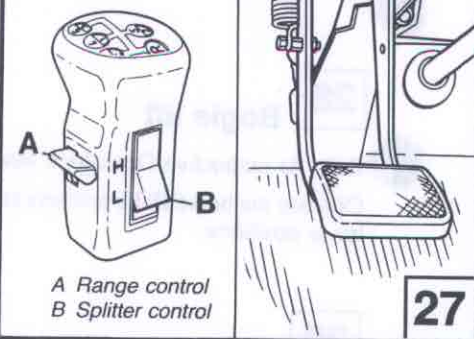

27

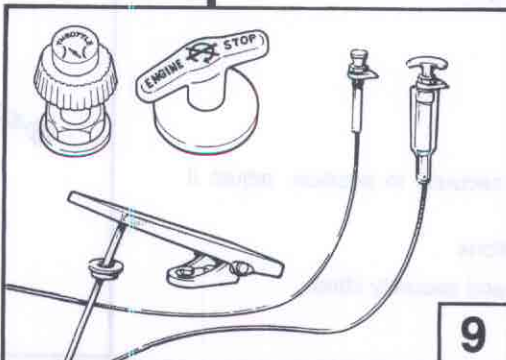

9

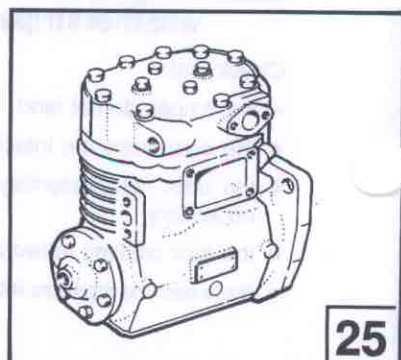

25

External checks

30 Headlamps

Check:

- condition of lamp lenses and reflectors
- headlight alignment. Adjust if necessary.
- lighting strength.

31 Air filter change, temperature control system

The air filter is placed behind the grille or service panel. On N-trucks, the filter is placed on the side of the engine bulkhead.

- Remove the screws for the air intake, remove the old filter and scrap it.
- Fit the new filter and tighten the screws.

32 Refrigerant cylinder, condenser, hoses

The check to be carried out when the temperature control system is in operation.

- Check that the white ball is at the top of the sight glass, indicating that the system has the correct quantity of refrigerant. The blue ball is a moisture indicator and changes to a pink colour if there is moisture in the system.
- Check the attachment of the condenser and refrigerant cylinder, also check the hoses and for possible leakage.

33 Air intake, roof spoiler

- Check that the inlet pipe is not damaged and that the rubber bellows seals against the air cleaner housing.
- Check that brackets and rubber pads are firmly attached, also check the bolting joints for the air intake and roof spoiler.
- Check that the rubber valves for the cyclone cleaner insert are in good condition and fit tightly.
Note! Air will not flow through the cleaner if a valve is leaking.
- Check that there are no cracks in the roof spoiler.

34 Cab attachment, cab suspension and the hydraulic system piping and hoses, cab tilt pump

- Visually check attachments to the frame.
Check that:
there there is no fault with the attachments
the shock absorbers do not leak

the springs are not broken
the torsion bar bolting is fully tightened.

- Check latch mechanism for cab attachment, split pins and bolts also warning contact. Test function. Also check cab front attachment, including shock absorbers, springs, rubber pads, bolting and grille condition and mounting.

Also check:

- The safety braces
- Levelling valve, pull rod and air line for cab levelling system. Also check attachment and for leakage.
- Hydraulic system pump. Also check that the piping and hoses for the cab tilting system are intact and do not leak.
- The safety latch function on the FL6 cab.
- The cab tilt pump. Tilt up the cab and check that the tilting function operates correctly.

35 Battery – mounting – connections – acid level

Check that:

- the batteries are clean and that no leakage is present
- the batteries are correctly secured. If the retaining bars are tightened too much, the battery casing can be deformed resulting in cracks.
- the fluid level is 5–10 mm over the cell plates. Top up with battery water if necessary. **Note!** Do not over-fill.
- the battery terminals are not corroded or broken. Clean the battery cable shoes. Grease the cable shoes or spray them with rustproofing.
- the cables are properly insulated and correctly wired.
- the earth cable is correctly anchored.

36 Battery, specific gravity Battery box, attachment

- Check battery specific gravity in each cell with a temperature-compensated hydrometer.
Note max and min gravities.

When assessing the battery, note any remarks made by the customer concerning any starting problems.

Maintenance-free batteries require special checking and charging procedures. Refer to the special instructions in the service literature.

- Check the condition of the battery box and its attachment.

37**Fuel tank, hoses, pipe and mounting bands**

Check that:

- there are no cracks or leakage
- the tank mounting bands and brackets are not loose or cracked
- pipes and hoses from the tank fuel level indicator are correctly clamped, do not leak and are not chafed.

38**Fuel tank – draining – suspension**

Condensation water is drained as follows:

1. Place a suitable container under the fuel tank bottom plug.
 2. Slacken the plug several turns until water starts running out. **Note!** Do not unscrew the plug fully otherwise you will empty the fuel tank.
 3. Screw tight the bottom plug when clean fuel runs out.
- Check that the fuel tank suspension brackets are securely attached and are not cracked.

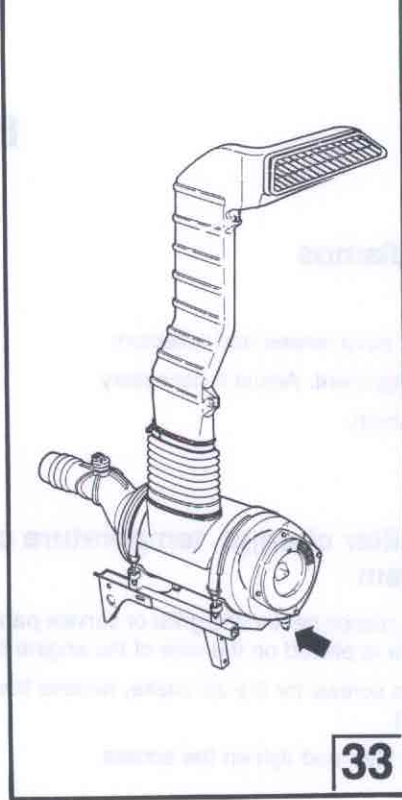
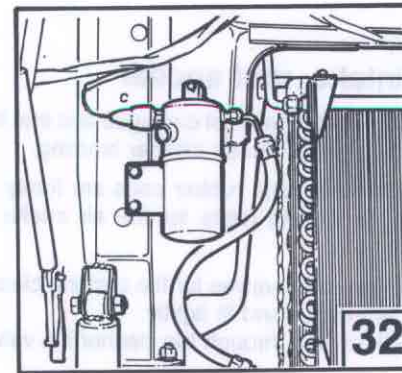
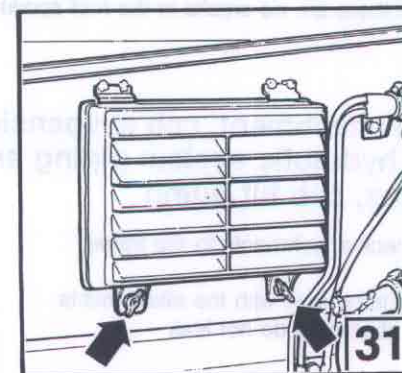
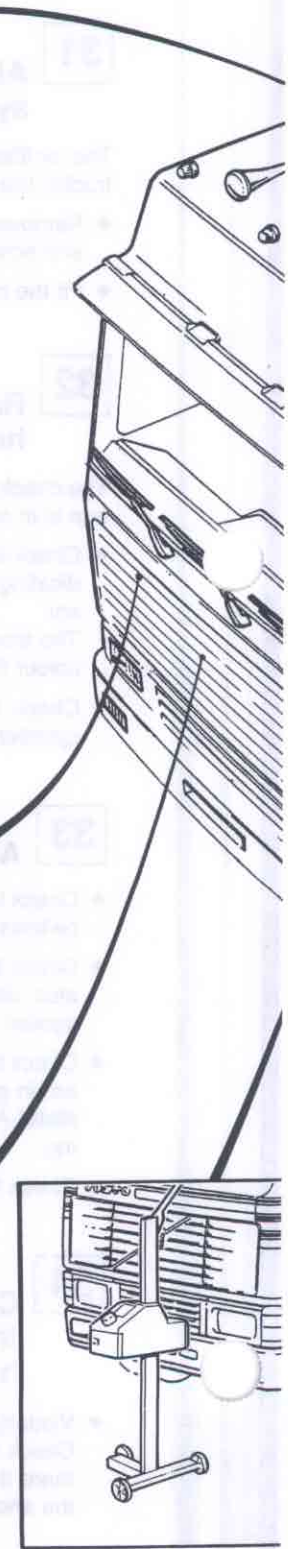
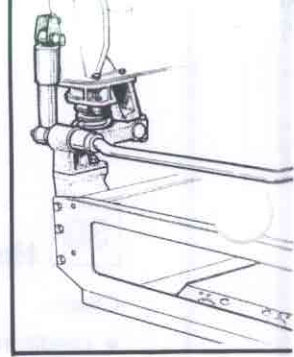
**33****33****32****31**

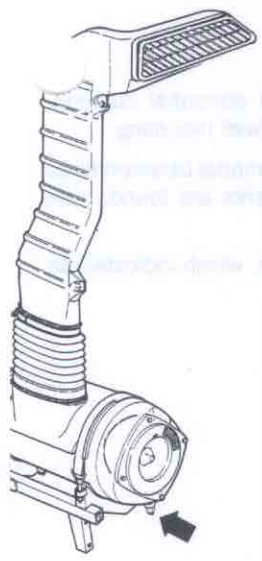

33

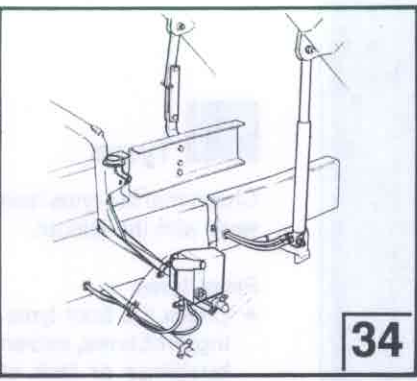
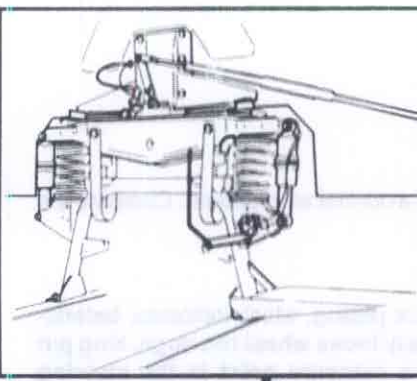
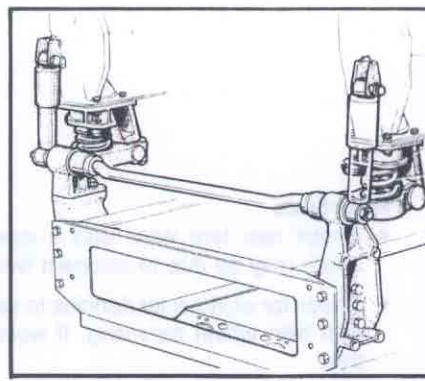

34



33

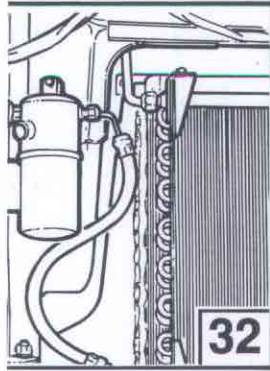

32

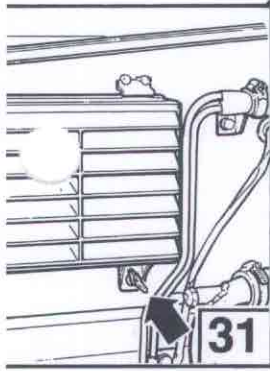

31

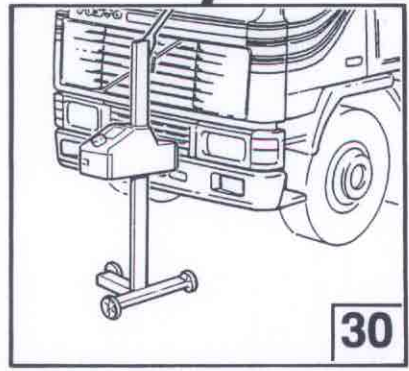

30

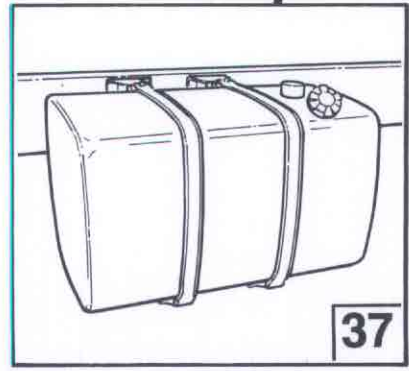

37

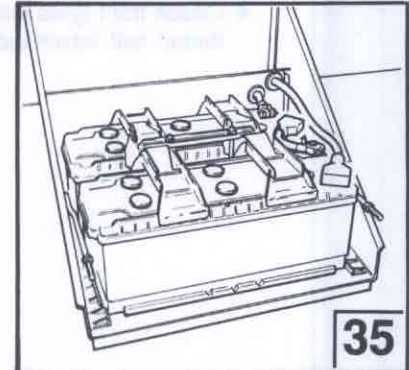

35

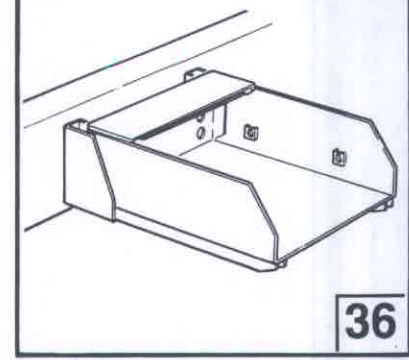
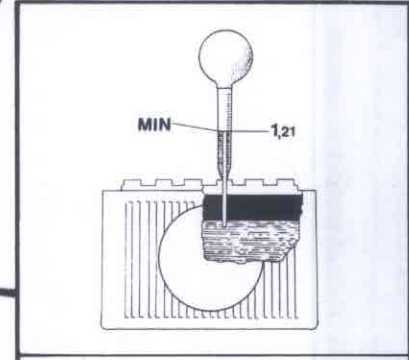

36

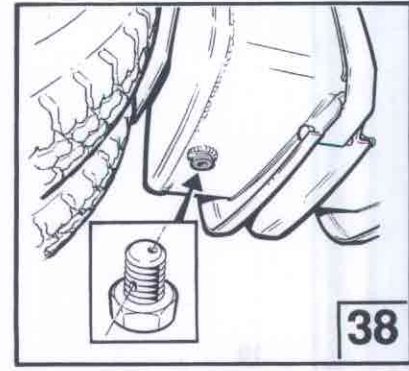

38

